



AMIS-42673

High Speed 3,3V Digital Interface CAN Transceiver

for Long Wire Networks

1.0 Introduction

The AMIS-42673 CAN transceiver is the interface between a controller area network (CAN) protocol controller and the physical bus. It may be used in both 12V and 24V systems. The digital interface level is powered from a 3.3V supply providing true I/O voltage levels for 3.3V CAN controllers.

The transceiver provides differential transmit capability to the bus and differential receive capability to the CAN controller. Due to the wide common-mode voltage range of the receiver inputs, the AMIS-42673 is able to reach outstanding levels of electromagnetic susceptibility (EMS). Similarly, extremely low electromagnetic emission (EME) is achieved by the excellent matching of the output signals.

The AMIS-42673 is primarily intended for applications where long network lengths are mandatory. Examples are elevators, in-building networks, process control and trains. To cope with the long bus delay the communication speed needs to be low. AMIS-42673 allows low transmit data rates down to 10 kbit/s or lower.

2.0 Key Features

- True 3,3V or 5,0V logic level interface
- Fully compatible with the “ISO 11898-2” standard
- Wide range of bus communication speed (0 up to 1Mbit/s)
- Allows low transmit data rate in networks exceeding 1 km
- Ideally suited for 12V and 24V applications
- Low electromagnetic emission (EME). Common-mode-choke is no longer required
- Differential receiver with wide common-mode range (+/- 35V) for high electromagnetic susceptibility (EMS)
- No disturbance of the bus lines with an un-powered node
- Thermal protection
- Bus pins protected against transients
- Short circuit proof to supply voltage and ground
- ESD protection for CAN bus at ± 8 kV

3.0 Technical Characteristics

Table 1: Technical Characteristics

Symbol	Parameter	Conditions	Min.	Max.	Unit
V_{CANH}	DC voltage at pin CANH	$0 < V_{CC} < 5.25V$; no time limit	-45	+45	V
V_{CANL}	DC voltage at pin CANL	$0 < V_{CC} < 5.25V$; no time limit	-45	+45	V
$V_i(\text{dif})(\text{bus_dom})$	Differential bus output voltage in dominant state	$42.5\Omega < R_{LT} < 60\Omega$	1.5	3	V
$t_{pd}(\text{rec-dom})$	Propagation delay TxD to RxD	Figure 7	100	230	ns
$t_{pd}(\text{dom-rec})$	Propagation delay TxD to RxD	Figure 7	100	245	ns
CM-range	Input common-mode range for comparator	Guaranteed differential receiver threshold and leakage current	-35	+35	V
$V_{CM\text{-peak}}$	Common-mode peak	Figure 8 and Figure 9 (Note 1)	-500	500	mV
$V_{CM\text{-step}}$	Common-mode step	Figure 8 and Figure 9 (Note 1)	-150	150	mV

Note 1: The parameters $V_{CM\text{-peak}}$ and $V_{CM\text{-step}}$ guarantee low EME.

AMIS-42673

4.0 Ordering Information

Part Number	Package	Shipping Configuration	Temperature Range
AMIS42673ICAG1G	SOIC-8 GREEN	Tube/Tray	-40°C...125°C
AMIS42673ICAG1RG	SOIC-8 GREEN	Tape & Reel	-40°C...125°C

5.0 Block Diagram

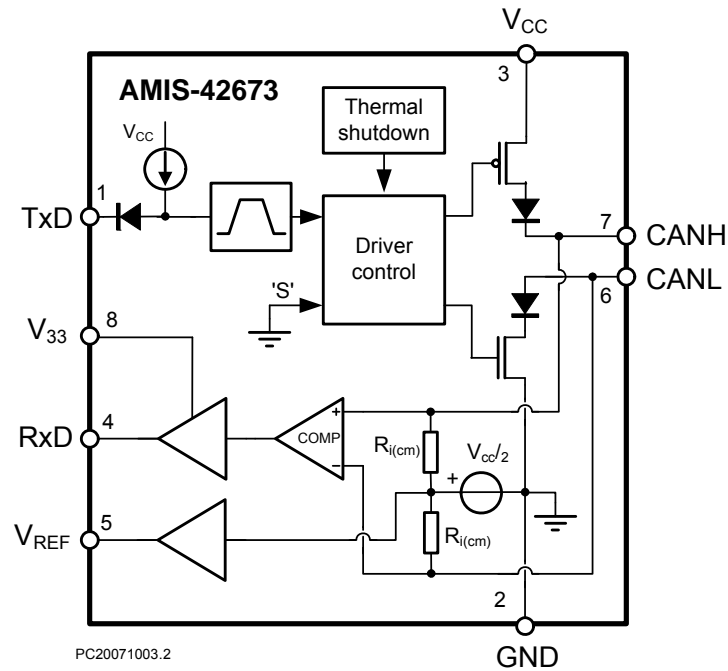
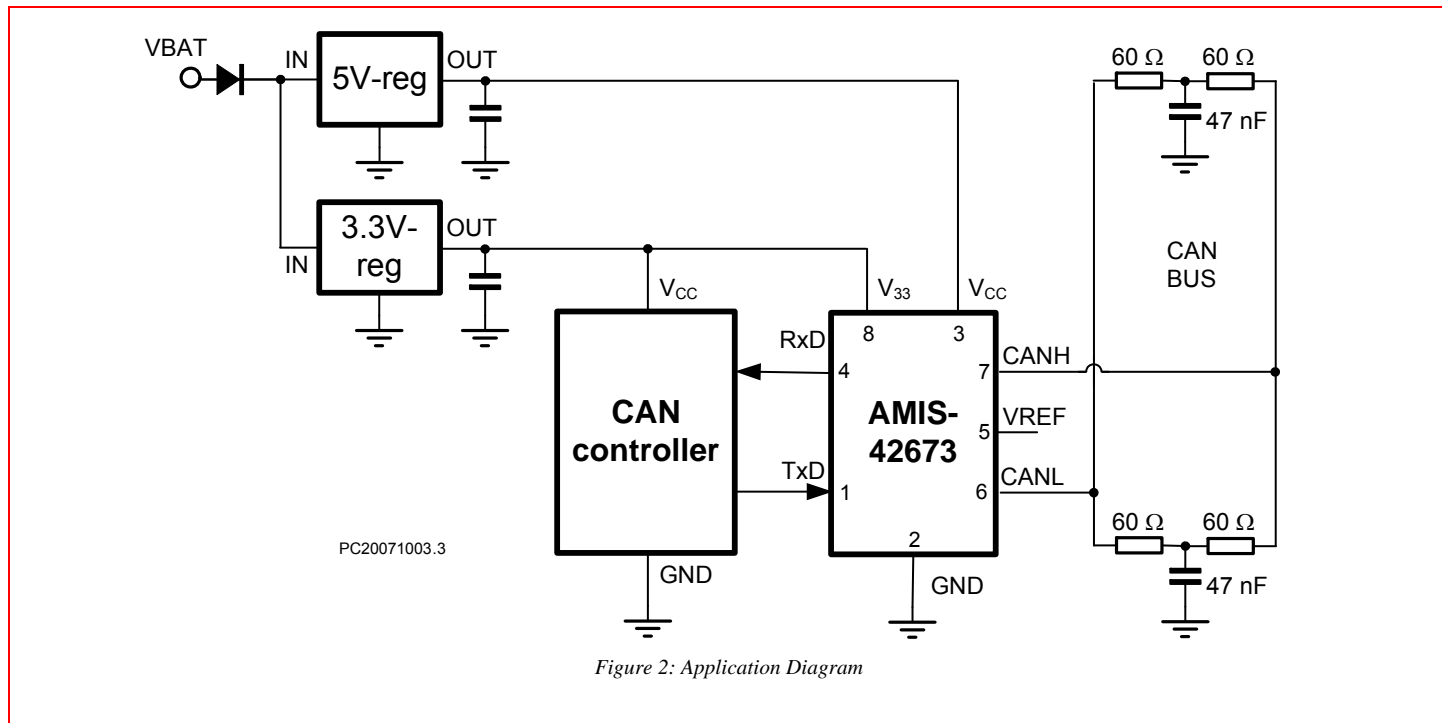

Figure 1: Block Diagram

AMIS-42673

6.0 Typical Application

6.1 Application Schematic



AMIS-42673

6.2 Pin Description

6.2.1. Pin Out (top view)

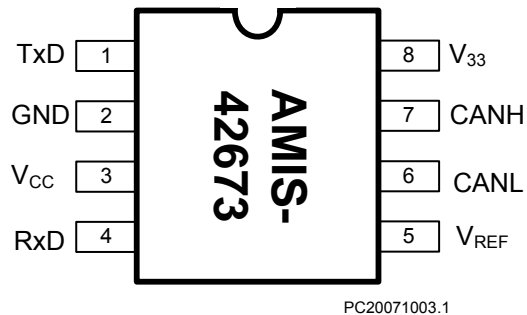

Figure 3: Pin Configuration

6.2.2. Pin Description

Table 2: Pin Out

Pin	Name	Description
1	TxD	Transmit data input; low input → dominant driver; internal pull-up current
2	GND	Ground
3	V _{CC}	Supply voltage
4	RxD	Receive data output; dominant transmitter → low output
5	V _{REF}	Reference voltage output
6	CANL	LOW-level CAN bus line (low in dominant mode)
7	CANH	HIGH-level CAN bus line (high in dominant mode)
8	V ₃₃	3.3V supply for digital I/O

AMIS-42673

7.0 Functional Description

7.1 General

The AMIS-42673 is the interface between the CAN protocol controller and the physical bus. It is intended for use in industrial and automotive applications requiring baud rates up to 1Mbit/s. It provides differential transmit capability to the bus and differential receiver capability to the CAN protocol controller. It is fully compatible to the "ISO 11898-2" standard.

7.2 Operating Modes

AMIS-42673 only operates in high-speed mode as illustrated in Table 3.

The transceiver is able to communicate via the bus lines. The signals are transmitted and received to the CAN controller via the pins TxD and RxD. The slopes on the bus lines outputs are optimised to give extremely low EME.

Table 3: Functional table of AMIS-42673; X = don't care

VCC	Pin TxD	Pin CANH	Pin CANL	Bus State	Pin RxD
4.75 to 5.25.V	0	High	Low	Dominant	0
4.75 to 5.25.V	1 (or floating)	VCC/2	VCC/2	Recessive	1
VCC<PORL (unpowered)	X	0V<CANH<VCC	0V<CANL<VCC	Recessive	1
PORL<VCC<4.75V	>2V	0V<CANH<VCC	0V<CANL<VCC	Recessive	1

7.3 Over-temperature Detection

A thermal protection circuit protects the IC from damage by switching off the transmitter if the junction temperature exceeds a value of approximately 160°C. Because the transmitter dissipates most of the power, the power dissipation and temperature of the IC is reduced. All other IC functions continue to operate. The transmitter off-state resets when pin TxD goes HIGH. The thermal protection circuit is particularly needed when a bus line short circuits.

7.4 High Communication Speed Range

The transceiver is primarily intended for industrial applications. It allows very low baud rates needed for long bus length applications. But also high speed communication is possible up to 1Mbit/s.

7.5 Fail-safe Features

A current-limiting circuit protects the transmitter output stage from damage caused by accidental short-circuit to either positive or negative supply voltage - although power dissipation increases during this fault condition.

The pins CANH and CANL are protected from automotive electrical transients (according to "ISO 7637"; see Figure 4).

Should TxD become disconnected, this pin is pulled high internally.

When the Vcc supply is removed, pins TxD and RxD will be floating. This prevents the AMIS-42673 from being supplied by the CAN controller through the I/O pins.

7.6 3.3V Interface

AMIS-42673 may be used to interface with 3.3V or 5V controllers by use of the V33 pin. This pin may be supplied with 3.3V or 5V to have the corresponding digital interface voltage levels.

When the V33 pin is supplied at 2.5V, even interfacing with 2.5V CAN controllers is possible. See also Digital Output Characteristics @ V33 = 2.5V, Table . In this case a pull-up resistor from TxD to V33 is necessary.

AMIS-42673

8.0 Electrical Characteristics

8.1 Definitions

All voltages are referenced to GND (pin 2). Positive currents flow into the IC. Sinking current means that the current is flowing into the pin. Sourcing current means that the current is flowing out of the pin.

8.2 Absolute Maximum Ratings

Stresses above those listed in Table 4 may cause permanent device failure. Exposure to absolute maximum ratings for extended periods may effect device reliability.

Table 4: Absolute Maximum Ratings

Symbol	Parameter	Conditions	Min.	Max.	Unit
V _{CC}	Supply voltage		-0.3	+7	V
V ₃₃	I/O interface voltage		-0.3	+7	V
V _{CANH}	DC voltage at pin CANH	0 < V _{CC} < 5.25V; no time limit	-45	+45	V
V _{CANL}	DC voltage at pin CANL	0 < V _{CC} < 5.25V; no time limit	-45	+45	V
V _{TxD}	DC voltage at pin TxD		-0.3	V _{CC} + 0.3	V
V _{RxD}	DC voltage at pin RxD		-0.3	V _{CC} + 0.3	V
VREF	DC voltage at pin VREF		-0.3	V _{CC} + 0.3	V
V _{tran(CANH)}	Transient voltage at pin CANH	Note 1	-150	+150	V
V _{tran(CANL)}	Transient voltage at pin CANL	Note 1	-150	+150	V
V _{tran(VREF)}	Transient voltage at pin VREF	Note 1	-150	+150	V
V _{esd(CANL/CANH)}	Electrostatic discharge voltage at CANH and CANL pin	Note 2 Note 5	-8 -500	+8 +500	kV V
V _{esd}	Electrostatic discharge voltage at all other pins	Note 3 Note 5	-4 -250	+4 +250	kV V
Latch-up	Static latch-up at all pins	Note 4		100	mA
T _{stg}	Storage temperature		-55	+155	°C
T _{amb}	Ambient temperature		-40	+125	°C
T _{junc}	Maximum junction temperature		-40	+150	°C

Notes:

- 1) Applied transient waveforms in accordance with "ISO 7637 part 3", test pulses 1, 2, 3a, and 3b (see Figure 4).
- 2) Standardized human body model system ESD pulses in accordance to IEC 1000.4.2.
- 3) Standardized human body model ESD pulses in accordance to MIL883 method 3015. Supply pin 8 is ±4kV.
- 4) Static latch-up immunity: static latch-up protection level when tested according to EIA/JESD78.
- 5) Standardized charged device model ESD pulses when tested according to EOS/ESD DS5.3-1993.

8.3 Thermal Characteristics

Table 5: Thermal Characteristics

Symbol	Parameter	Conditions	Value	Unit
R _{th(vj-a)}	Thermal resistance from junction to ambient in SO8 package	In free air	145	K/W
R _{th(vj-s)}	Thermal resistance from junction to substrate of bare die	In free air	45	K/W

AMIS-42673

8.4 DC Characteristics

$V_{CC} = 4.75$ to $5.25V$; $V_{33} = 2.9V$ to $3.6V$; $T_{junc} = -40$ to $+150$ °C; $R_{LT} = 60\Omega$ unless specified otherwise

Table 6: Characteristics

Symbol	Parameter	Conditions	Min.	Typ.	Max.	Unit
Supply (pin V_{CC} and pin V_{33})						
I_{CC}	Supply current	Dominant; $V_{TXD} = 0V$ Recessive; $V_{TXD} = V_{CC}$		45 4	65 8	mA mA
I_{33}	I/O interface current	$V_{33} = 3.3V$; $C_L = 20pF$; recessive			1	μA
I_{33}	I/O interface current ⁽¹⁾	$V_{33} = 3.3V$; $C_L = 20pF$; 1Mbps			170	μA
Transmitter Data Input (pin TxD)						
V_{IH}	HIGH-level input voltage	Output recessive	2.0	-	V_{CC}	V
V_{IL}	LOW-level input voltage	Output dominant	-0.3	-	+0.8	V
I_{IH}	HIGH-level input current	$V_{TXD} = V_{33}$	-1	0	+1	μA
I_{IL}	LOW-level input current	$V_{TXD} = 0V$	-50	-200	-300	μA
C_i	Input capacitance ⁽¹⁾		-	5	10	pF
Receiver Data Output (pin RxD)						
V_{OH}	HIGH-level output voltage	$I_{RXD} = -10mA$	$0.7 \times V_{33}$	$0.75 \times V_{33}$		V
V_{OL}	LOW-level output voltage	$I_{RXD} = 5mA$		0.18	0.35	V
I_{oh}	HIGH-level output current ⁽¹⁾	$V_{RXD} = 0.7 \times V_{33}$	-10	-15	-20	mA
I_{ol}	LOW-level output current ⁽¹⁾	$V_{RXD} = 0.45V$	5	10	15	mA
Reference Voltage Output (pin V_{REF})						
V_{REF}	Reference output voltage	$-50\mu A < I_{VREF} < +50\mu A$	$0.45 \times V_{CC}$	$0.50 \times V_{CC}$	$0.55 \times V_{CC}$	V
V_{REF_CM}	Reference output voltage for full common-mode range	$-35V < V_{CANH} < +35V$; $-35V < V_{CANL} < +35V$	$0.40 \times V_{CC}$	$0.50 \times V_{CC}$	$0.60 \times V_{CC}$	V
Bus Lines (pins CANH and CANL)						
$V_{o(reces)(CANH)}$	Recessive bus voltage at pin CANH	$V_{TXD} = V_{CC}$; no load	2.0	2.5	3.0	V
$V_{o(reces)(CANL)}$	Recessive bus voltage at pin CANL	$V_{TXD} = V_{CC}$; no load	2.0	2.5	3.0	V
$I_{o(reces)(CANH)}$	Recessive output current at pin CANH	$-35V < V_{CANH} < +35V$; $0V < V_{CC} < 5.25V$	-2.5	-	+2.5	mA
$I_{o(reces)(CANL)}$	Recessive output current at pin CANL	$-35V < V_{CANL} < +35V$; $0V < V_{CC} < 5.25V$	-2.5	-	+2.5	mA
$V_{o(dom)(CANH)}$	Dominant output voltage at pin CANH	$V_{TXD} = 0V$	3.0	3.6	4.25	V
$V_{o(dom)(CANL)}$	Dominant output voltage at pin CANL	$V_{TXD} = 0V$	0.5	1.4	1.75	V
$V_{i(dif)(bus)}$	Differential bus input voltage ($V_{CANH} - V_{CANL}$)	$V_{TXD} = 0V$; dominant; $42.5\Omega < R_{LT} < 60\Omega$	1.5	2.25	3.0	V
		$V_{TXD} = V_{CC}$; recessive; no load	-120	0	+50	mV
$I_{o(sc)(CANH)}$	Short circuit output current at pin CANH	$V_{CANH} = 0V$; $V_{TXD} = 0V$	-45	-70	-95	mA
$I_{o(sc)(CANL)}$	Short circuit output current at pin CANL	$V_{CANL} = 36V$; $V_{TXD} = 0V$	45	70	120	mA
$V_{i(dif)(th)}$	Differential receiver threshold voltage	$-5V < V_{CANL} < +12V$; $-5V < V_{CANH} < +12V$; see Figure 5	0.5	0.7	0.9	V
$V_{ihcm(dif)(th)}$	Differential receiver threshold voltage for high common-mode	$-35V < V_{CANL} < +35V$; $-35V < V_{CANH} < +35V$; see Figure 5	0.25	0.7	1.05	V
$V_{i(dif)(hys)}$	Differential receiver input voltage hysteresis	$-35V < V_{CANL} < +35V$; $-35V < V_{CANH} < +35V$; see Figure 5	50	70	100	mV
$R_{i(cm)(CANH)}$	Common-mode input resistance at pin CANH		15	25	37	K Ω
$R_{i(cm)(CANL)}$	Common-mode input resistance at pin CANL		15	25	37	K Ω
$R_{i(cm)(m)}$	Matching between pin CANH and pin CANL common-mode input resistance	$V_{CANH} = V_{CANL}$	-3	0	+3	%
$R_{i(dif)}$	Differential input resistance		25	50	75	K Ω

AMIS-42673

Table 6: Characteristics (Continued)

Symbol	Parameter	Conditions	Min.	Typ.	Max.	Unit
Bus Lines (pins CANH and CANL)						
$C_{i(CANH)}$	Input capacitance at pin CANH	$V_{TxD} = V_{CC}$; not tested		7.5	20	pF
$C_{i(CANL)}$	Input capacitance at pin CANL	$V_{TxD} = V_{CC}$; not tested		7.5	20	pF
$C_{i(dif)}$	Differential input capacitance	$V_{TxD} = V_{CC}$; not tested		3.75	10	pF
$I_{Ll(CANH)}$	Input leakage current at pin CANH	$V_{CC} = 0V$; $V_{CANH} = 5V$	10	170	250	μA
$I_{Ll(CANL)}$	Input leakage current at pin CANL	$V_{CC} = 0V$; $V_{CANL} = 5V$	10	170	250	μA
$V_{CM-peak}$	Common-mode peak during transition from dom \rightarrow rec or rec \rightarrow dom	Figure 8 and Figure 9	-500		500	mV
$V_{CM-step}$	Difference in common-mode between dominant and recessive state	Figure 8 and Figure 9	-150		150	mV
Power-on-Reset						
PORL	POR level	CANH, CANL, V_{ref} in tri-state below POR level	2.2	3.5	4.7	V
Thermal Shutdown						
$T_{j(sd)}$	shutdown junction temperature		150	160	180	$^{\circ}C$
Timing Characteristics (see Figures 6 and 7)						
$t_{d(TxD-BUSon)}$	Delay TxD to bus active		40	85	110	ns
$t_{d(TxD-BUSoff)}$	Delay TxD to bus inactive		30	60	110	ns
$t_{d(BUSon-RxD)}$	Delay bus active to RxD		25	55	110	ns
$t_{d(BUSoff-RxD)}$	Delay bus inactive to RxD		65	100	135	ns
$t_{pd(rec-dom)}$	Propagation delay TxD to RxD from recessive to dominant		100		230	ns
$t_{d(dom-rec)}$	Propagation delay TxD to RxD from dominant to recessive		100		245	ns

Note: 1) Not tested at ATE

$V_{CC} = 4.75$ to $5.25V$; $V_{33} = 2.5V \pm 5\%$; $T_{junc} = -40$ to $+150^{\circ}C$; $R_{LT} = 60\Omega$ unless specified otherwise.

Table 7: Digital Output Characteristics @ $V_{33} = 2.5V$

Symbol	Parameter	Conditions	Min.	Typ.	Max.	Unit
Receiver Data Output (pin RxD)						
I_{oh}	HIGH-level output current	$V_{OH} > 0.9 \times V_{33}$	-2.6			mA
I_{ol}	LOW-level output current	$V_{OL} < 0.1 \times V_{33}$			4	mA

8.5 Measurement Set-ups and Definitions

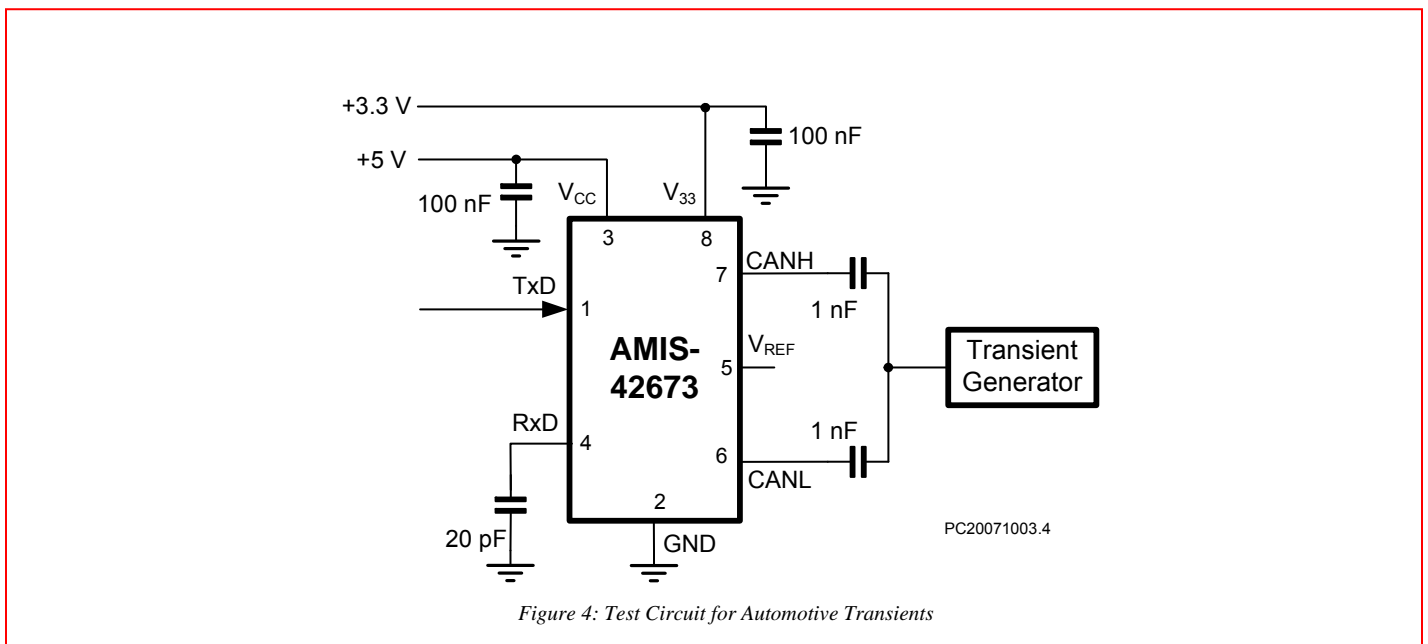

Figure 4: Test Circuit for Automotive Transients

AMIS-42673

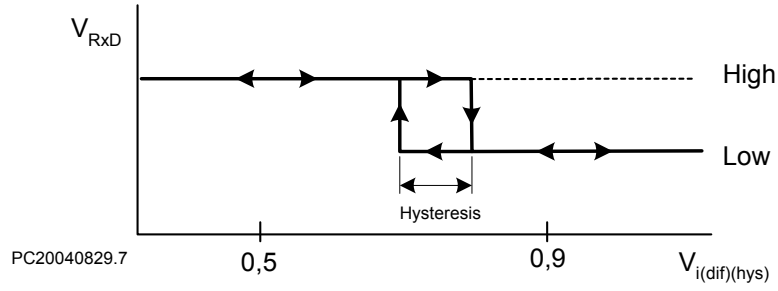

Figure 5: Hysteresis of the Receiver

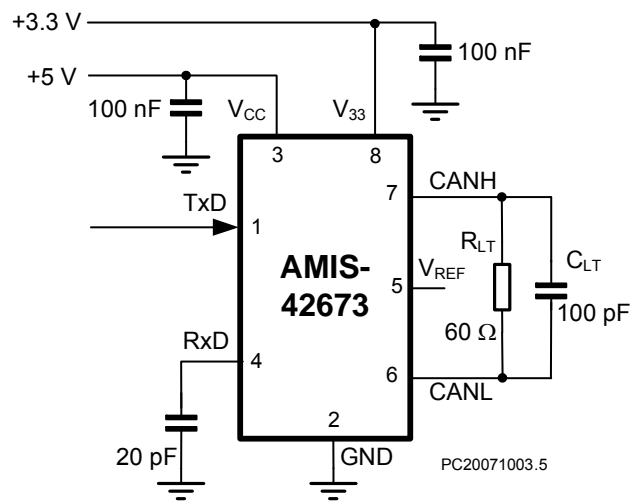
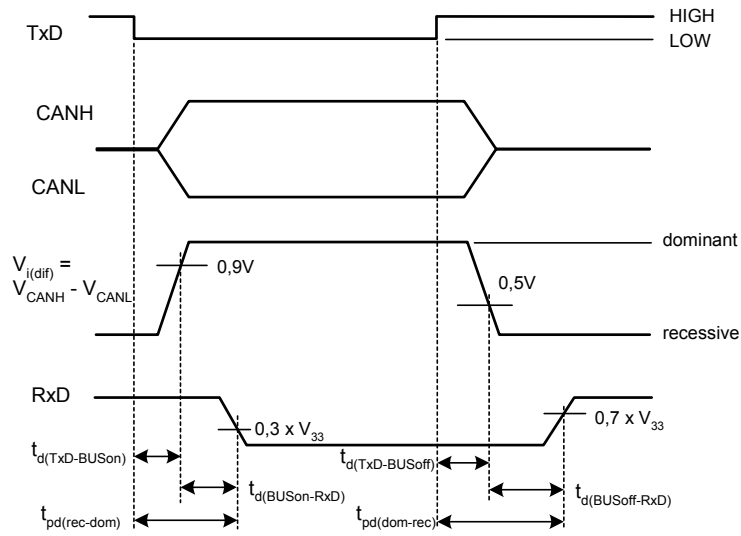

Figure 6: Test Circuit for Timing Characteristics

AMIS-42673



PC20040829.6

Figure 7: Timing Diagram for AC Characteristics

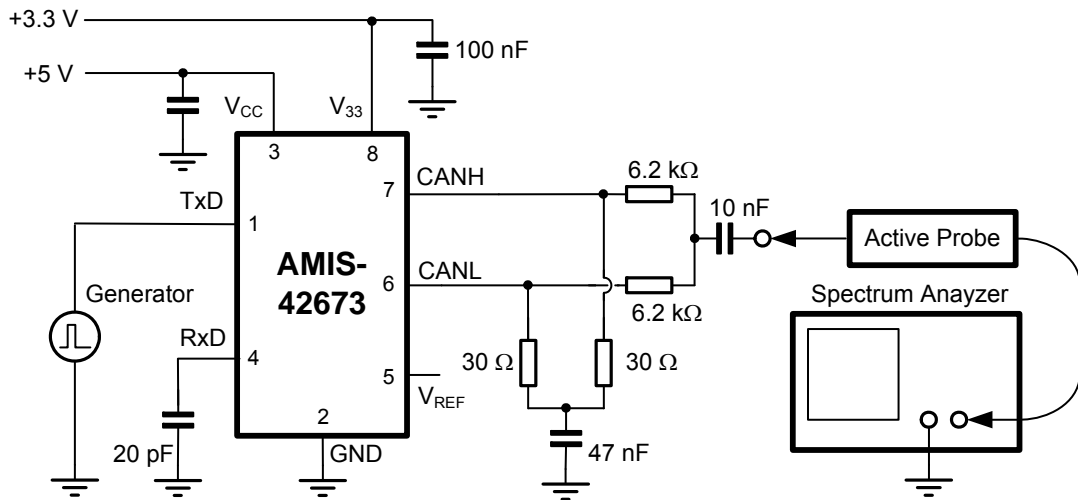

PC20071003.6

Figure 8: Basic Test Set-up for Electromagnetic Measurement

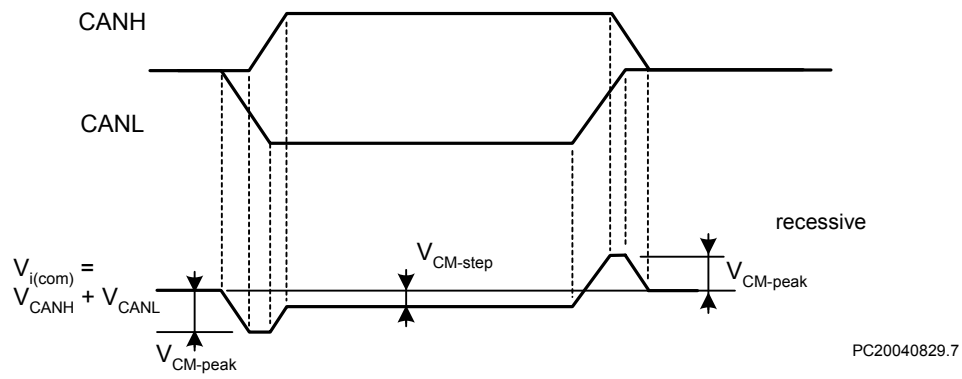
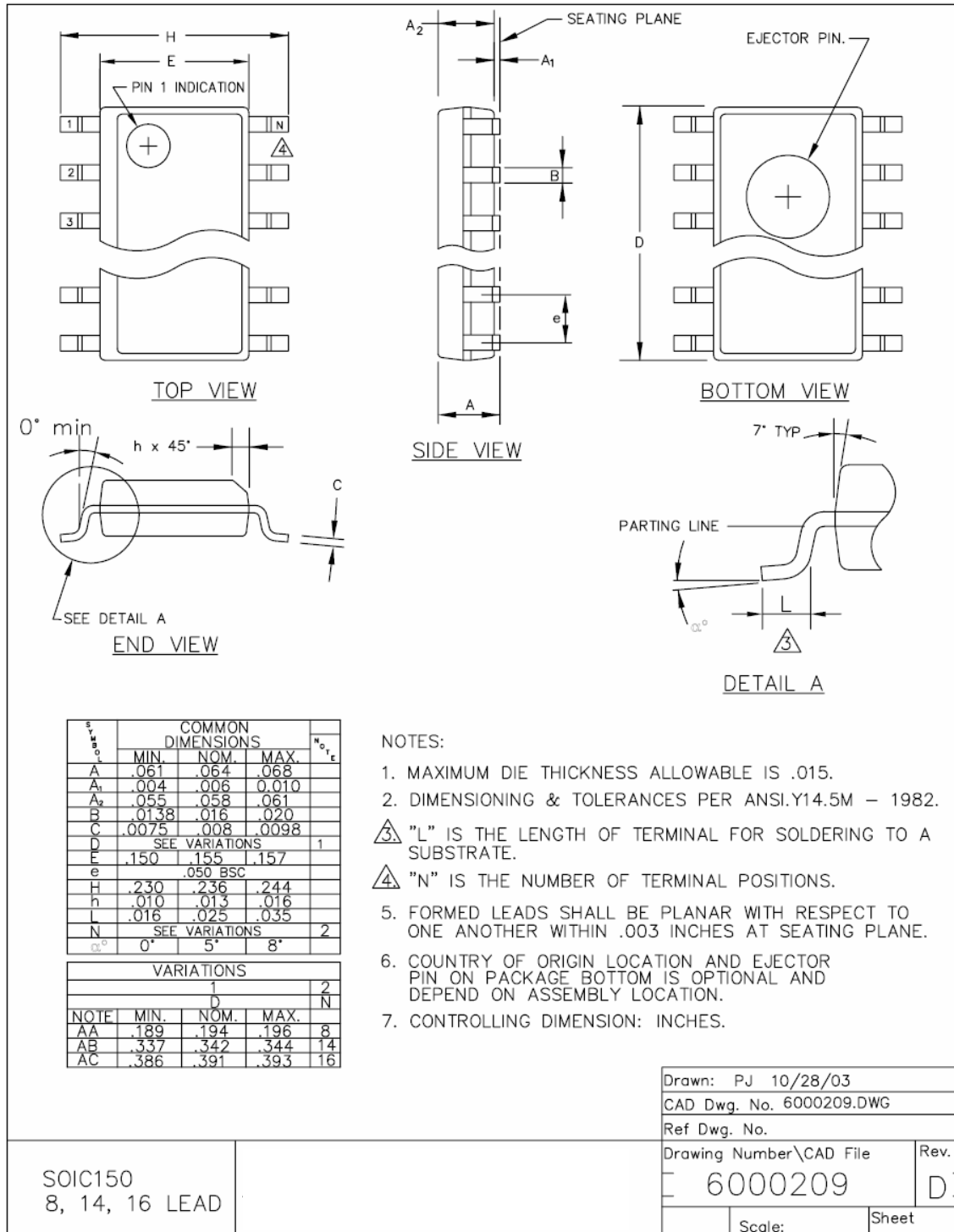

Figure 9: Common-mode Voltage Peaks (see measurement set-up Figure 8)

AMIS-42673

9.0 Package Outline

SOIC-8: Plastic small outline; 8 leads; body width 150 mil; JEDEC: MS-012



AMIS-42673

10.0 Soldering

10.1 Introduction to Soldering Surface Mount Packages

This text gives a very brief insight to a complex technology. A more in-depth account of soldering ICs can be found in the AMIS “Data Handbook IC26; Integrated Circuit Packages” (document order number 9398 652 90011). There is no soldering method that is ideal for all surface mount IC packages. Wave soldering is not always suitable for surface mount ICs, or for printed-circuit boards (PCB) with high population densities. In these situations re-flow soldering is often used.

10.2 Re-flow Soldering

Reflow soldering requires solder paste (a suspension of fine solder particles, flux and binding agent) to be applied to the PCB by screen printing, stencilling or pressure-syringe dispensing before package placement. Several methods exist for re-flowing; for example, infrared/convection heating in a conveyor type oven.

Throughput times (preheating, soldering and cooling) vary between 100 and 200 seconds depending on heating method. Typical re-flow peak temperatures range from 215 to 250°C. The top-surface temperature of the packages should preferably be kept below 230°C.

10.3 Wave Soldering

Conventional single wave soldering is not recommended for surface mount devices (SMDs) or PCBs with a high component density, as solder bridging and non-wetting can present major problems. To overcome these problems the double-wave soldering method was specifically developed. If wave soldering is used the following conditions must be observed for optimal results:

- Use a double-wave soldering method comprising a turbulent wave with high upward pressure followed by a smooth laminar wave.
- For packages with leads on two sides and a pitch (e):
 - Larger than or equal to 1.27mm, the footprint longitudinal axis is preferred to be parallel to the transport direction of the PCB;
 - Smaller than 1.27mm, the footprint longitudinal axis must be parallel to the transport direction of the PCB. The footprint must incorporate solder thieves at the downstream end.
- For packages with leads on four sides, the footprint must be placed at a 45° angle to the transport direction of the PCB. The footprint must incorporate solder thieves downstream and at the side corners.

During placement and before soldering, the package must be fixed with a droplet of adhesive. The adhesive can be applied by screen printing, pin transfer or syringe dispensing. The package can be soldered after the adhesive is cured. Typical dwell time is four seconds at 250°C. A mildly-activated flux will eliminate the need for removal of corrosive residues in most applications.

10.4 Manual Soldering

Fix the component by first soldering two diagonally-opposite end leads. Use a low voltage (24V or less) soldering iron applied to the flat part of the lead. Contact time must be limited to 10 seconds at up to 300°C.

When using a dedicated tool, all other leads can be soldered in one operation within two to five seconds between 270 and 320°C.

Table 8: Soldering Process

Package	Soldering Method	
	Wave	Re-flow ⁽¹⁾
BGA, SQFP	Not suitable	Suitable
HLQFP, HSQFP, HSOP, HTSSOP, SMS	Not suitable ⁽²⁾	Suitable
PLCC ⁽³⁾ , SO, SOJ	Suitable	Suitable
LQFP, QFP, TQFP	Not recommended ⁽³⁾⁽⁴⁾	Suitable
SSOP, TSSOP, VSO	Not recommended ⁽⁵⁾	Suitable

- Notes
1. All surface mount (SMD) packages are moisture sensitive. Depending upon the moisture content, the maximum temperature (with respect to time) and body size of the package, there is a risk that internal or external package cracks may occur due to vaporization of the moisture in them (the so called popcorn effect). For details, refer to the drypack information in the “Data Handbook IC26; Integrated Circuit Packages; Section: Packing Methods.”
 2. These packages are not suitable for wave soldering as a solder joint between the PCB and heatsink (at bottom version) can not be achieved, and as solder may stick to the heatsink (on top version).
 3. If wave soldering is considered, then the package must be placed at a 45° angle to the solder wave direction. The package footprint must incorporate solder thieves downstream and at the side corners.
 4. Wave soldering is only suitable for LQFP, TQFP and QFP packages with a pitch (e) equal to or larger than 0.8mm; it is definitely not suitable for packages with a pitch (e) equal to or smaller than 0.65mm.
 5. Wave soldering is only suitable for SSOP and TSSOP packages with a pitch (e) equal to or larger than 0.65mm; it is definitely not suitable for packages with a pitch (e) equal to or smaller than 0.5mm.

AMIS-42673

11.0 Revision History

Date	Revision	Change
October 2007	1.0	Initial release
June 2007	2.0	Update content to ON Semiconductor template; update OPN table

12.0 Company or Product Inquiries

For more information about ON Semiconductor's products or services visit our Web site at <http://onsemi.com>.

ON Semiconductor and  are registered trademarks of Semiconductor Components Industries, LLC (SCILLC). SCILLC reserves the right to make changes without further notice to any products herein. SCILLC makes no warranty, representation or guarantee regarding the suitability of its products for any particular purpose, nor does SCILLC assume any liability arising out of the application or use of any product or circuit, and specifically disclaims any and all liability, including without limitation special, consequential or incidental damages. "Typical" parameters which may be provided in SCILLC data sheets and/or specifications can and do vary in different applications and actual performance may vary over time. All operating parameters, including "Typicals" must be validated for each customer application by customer's technical experts. SCILLC does not convey any license under its patent rights nor the rights of others. SCILLC products are not designed, intended, or authorized for use as components in systems intended for surgical implant into the body, or other applications intended to support or sustain life, or for any other application in which the failure of the SCILLC product could create a situation where personal injury or death may occur. Should Buyer purchase or use SCILLC products for any such unintended or unauthorized application, Buyer shall indemnify and hold SCILLC and its officers, employees, subsidiaries, affiliates, and distributors harmless against all claims, costs, damages, and expenses, and reasonable attorney fees arising out of, directly or indirectly, any claim of personal injury or death associated with such unintended or unauthorized use, even if such claim alleges that SCILLC was negligent regarding the design or manufacture of the part. SCILLC is an Equal Opportunity/Affirmative Action Employer. This literature is subject to all applicable copyright laws and is not for resale in any manner.

PUBLICATION ORDERING INFORMATION

LITERATURE FULFILLMENT:

Literature Distribution Center for ON Semiconductor
P.O. Box 5163, Denver, Colorado 80217 USA
Phone: 303-675-2175 or 800-344-3860 Toll Free USA/Canada
Fax: 303-675-2176 or 800-344-3867 Toll Free USA/Canada
Email: orderlit@onsemi.com

N. American Technical Support: 800-282-9855
Toll Free USA/Canada
Europe, Middle East and Africa Technical Support:
Phone: 421 33 790 2910
Japan Customer Focus Center
Phone: 81-3-5773-3850

ON Semiconductor Website: www.onsemi.com

Order Literature: <http://www.onsemi.com/orderlit>

For additional information, please contact your local Sales Representative